

Atlantium's HOD systems protect Palma Aquarium from parasite outbreak and ensure compliance with environmental regulations

In June 2007, Coral World International opened its newest and most advanced aquarium in Palma de Mallorca, Spain. With over 30 years of experience in professional aquarium development, Coral World understands that water quality is a key factor in ocean settings and maintaining this quality is an essential requisite for reproducing different habitats at Palma Aquarium. It was with this understanding that it chose Atlantium's Hydro-Optic Disinfection (HOD) systems for its New World section.

The New World section of the Palma Aquarium has 24 aquaria housing corals, anemones, invertebrates, sponges, small organisms, deep-sea animals, benthos species and countless other creatures. The aquarium is supplied by sea water, with a re-circulation flow rate of 63 m³/hr, and a make-up and effluent rate of 10 m³/hr. The UV transmittance of the water is 95%.

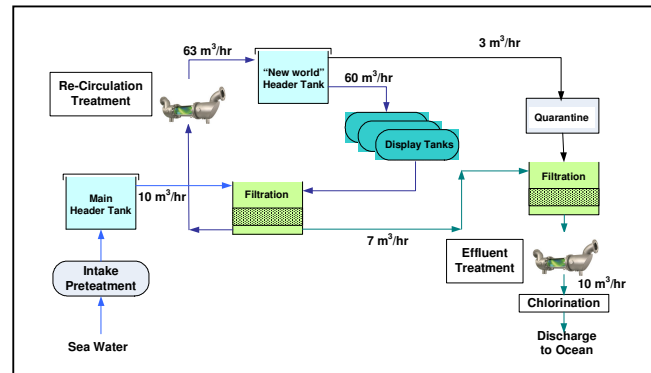

Simplified layout of Palma Aquarium's New World area

Atlantium's HOD systems form an integral part of New World's re-circulation and effluent water disinfection processes. Both applications use Atlantium's R-100 Single Lamp system.

1. HOD re-circulation application maintains low microbial loads and protects the aquarium population

As part of the aquarium's re-circulation process, Atlantium's HOD system maintains low microbial load in the aquariums, protecting the New World population from severe microbial threats, including viruses, fungi, bacteria and parasites and preventing disease outbreaks. These are major concerns, as the eco-system within the aquarium is highly sensitive and must be protected carefully. Additionally, contamination can spread rapidly, infecting the entire aquarium.

The impact of Atlantium's HOD system was quite evident when, after a short time without hydro-optic disinfection, a parasite outbreak quickly developed on the fish in the aquarium's tanks. Once the disinfection was re-introduced, the parasite population returned to normal levels.

"Atlantium's HOD system is vital to the health of our aquarium's fish population. We noticed that after a short time when Atlantium's system was off we rapidly developed an explosion in parasite numbers. We were extremely relieved that soon after we re-activated the system, the parasite numbers came under control again"

Aharon Miroz
Chief Curator for Coral World International

Another major advantage of Atlantium's HOD system is that it is very friendly to corals. Unlike other water treatment systems that can be very aggressive, the HOD system has no detrimental effects on the corals in the display tanks.

2. HOD effluent treatment application minimizes the impact on the surrounding environment

Since the New World aquarium houses fish from the Indian, Atlantic and Pacific Oceans, measures must be taken to prevent any foreign bacteria being introduced to the Mediterranean's natural eco-system. By using Atlantium's HOD systems to treat the aquarium's effluent, Coral World is able to meet environmental regulations and protect its surroundings.

HOD – achieving superior microbial reduction

Atlantium HOD systems are able to effectively inactivate pathogens – while still being environmentally friendly, cost-effective and not introducing any disinfection by-products into the aquarium. This is achieved by combining ultraviolet water disinfection technology with hydraulic and optic principles. The core of the HOD system is a large quartz tube that acts as an effective light trap, reflecting stray UV light back into the mid-section of the unit using the concept of "total internal reflection". This creates a homogeneous uniform distribution of the UV light throughout the system's cross-section at a dosage that systematically achieves unprecedented micro-organism inactivation.

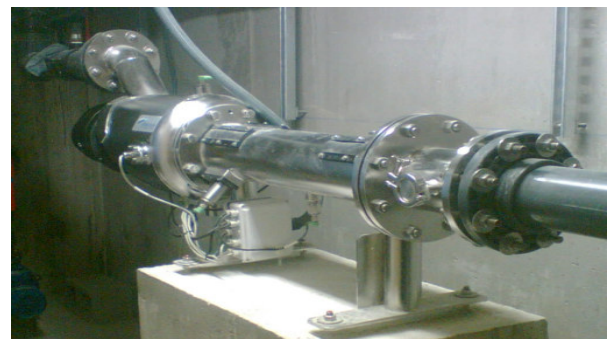

R-100 Single Lamp treating New World's effluent